

SIDE VIEW MODEL DESIGNED FOR MONITORING TEMPERATURE IN DIRTY OR VAPOR-FILLED ENVIRONMENTS

IRt/c.3SV

In heating, drying, coating, cooling, or any other thermal processing of webs of paper, plastic, metals, textiles, film, etc., often there is very little space available for a sensor to monitor web temperature, and the harsh environment requires a highly efficient air purge design to prevent fouling of the IR lens. In a space as small as 0.7 in. (18 mm), and in areas where ink or paint are being applied, the IRt/c.3SV Infrared Thermocouple can reliably control the process to maximize quality and throughput of product.

The IRt/c.3SV has all of the same specifications as the standard IRt/c, including no power requirement, rugged stainless steel hermetically sealed construction, intrinsically safe, full electrical shielding, ~0.1 second response time, and ability to operate uncooled in environments up to 212°F (100°C). It is available in J, K, T, E thermocouple types, with linear range selections the same as the standard IRt/c. The solid filled 1/2 in. (12.7 mm) tubular housing can be held securely with convenient tube fittings or standard clamps to mount the sensor over the target area.

Ideal applications are offset printing, where the presence of inks and physically tight locations make the IRt/c.3SV the sensor of choice. Targets that must be monitored “upside down” are also ideal applications, since the narrow field of view and air purge will prevent debris from blocking the lens. Only 5 psig (.3 bar), which consumes less than 1 SCFM (.03 m³/min) is required for direct paint spray environments.

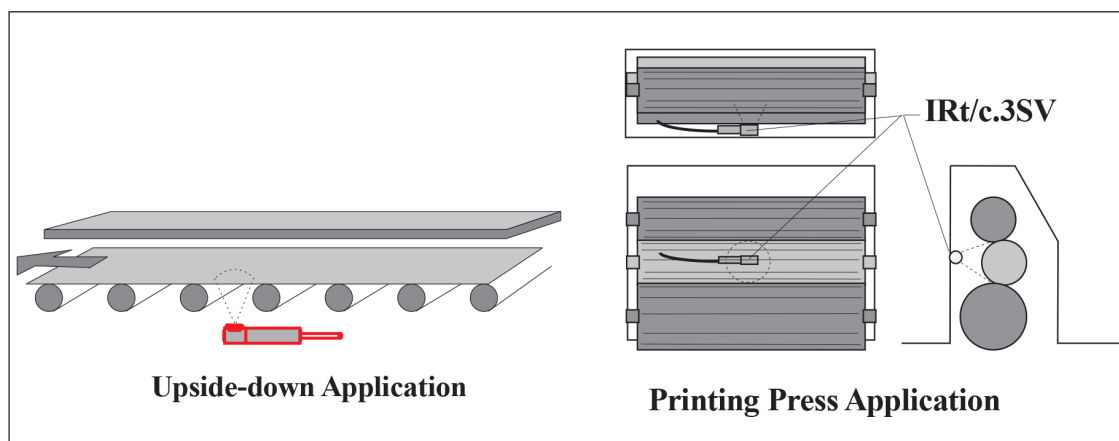
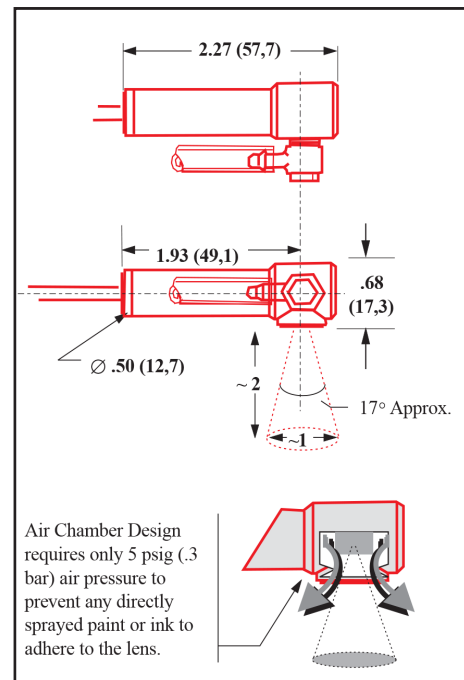

Exergen Corporation office:

USA
400 Pleasant Street
Watertown, MA 02472
Tel: +1 617 923 9900 press 4 for industrial
Fax: +1 617 923 9911

Exergen Industrial International/OEM Sales office:

Clever IR
The Netherlands
Pastoor Clercxstraat 26
5465 RH Veghel
Tel: +31 (0)413 376 599

industrial@exergen.com
www.exergen.com

TN-083-1-EN